

Calculation of breakdown voltage (Test acc. To IEC 60851.5.4.2, cylinder)

The breakdown voltage depends mainly on the thickness of the insulation (see formula), but also on the bare wire diameter, the application temperature of the coil and the type of enamel.

Calculation of average values D_s :

$D_s = t \times V_{\mu}$ [Volt], with

D_s : breakdown voltage

T : increase due to insulation, $t = d_a - d_{nom}$, with

d_a : outer diameter

d_{nom} : bare wire diameter

V_{μ} : Volt per micron insulation,

Example: Test with cylindrical electrode

$d_{nom} = 0.071\text{mm}$

$d_a = 0.083\text{mm}$

$t = d_a - d_{nom} = 0.083 - 0.071 = 0.012\text{mm} = 12\mu\text{m}$

$V_{\mu} = 205 \text{ V}/\mu\text{m}$, therefore

$D_s = 12\mu \times 205 \text{ V}/\mu = 2,460 \text{ V}$

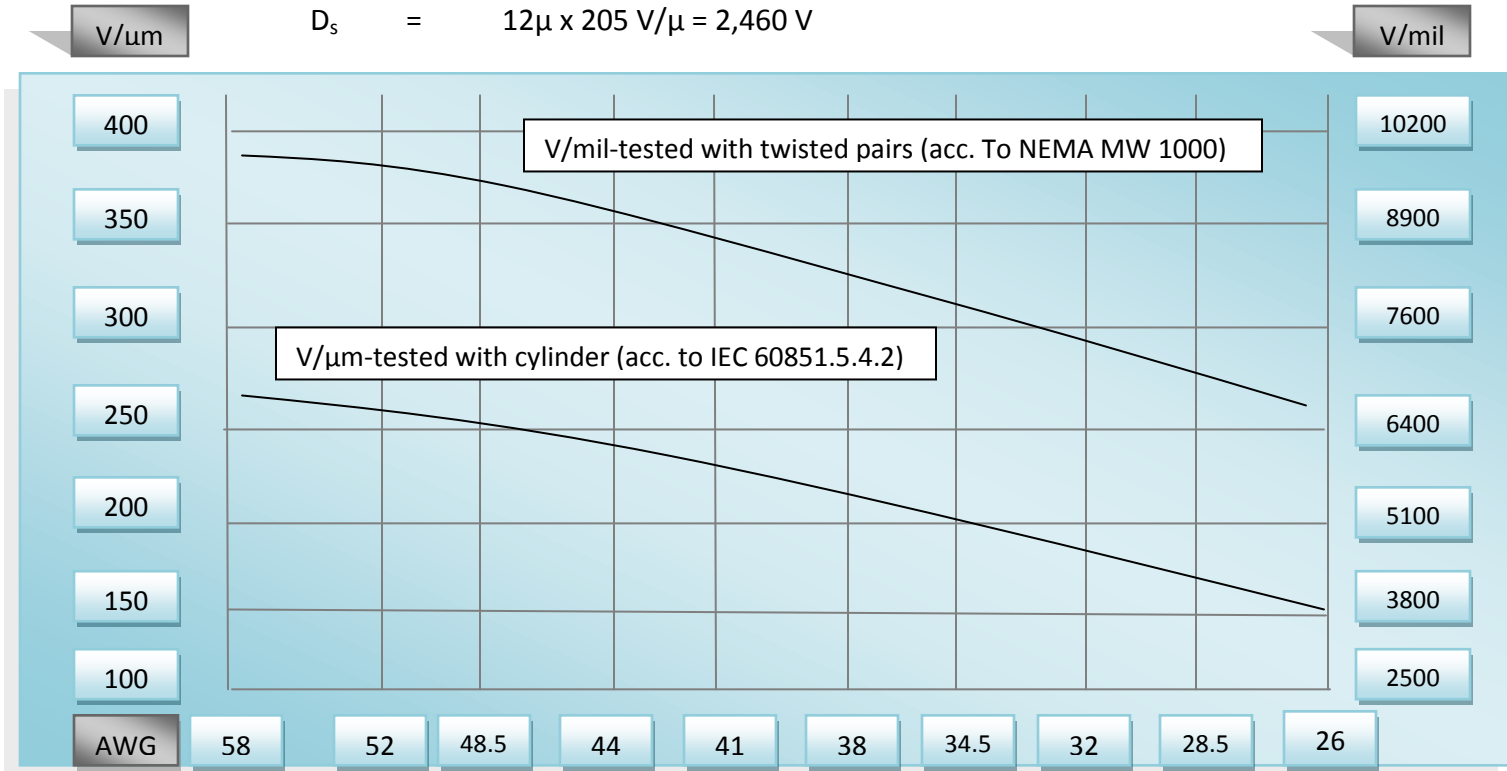

Breakdown voltage

- Meaning

The breakdown voltage is of highest importance for the magnet wire as it directly indicates the dielectric strength of the enamel insulation.

The value depends on the insulation thickness. The breakdown voltage increases as the insulation thickness increases. Higher ambient temperatures result in a reduction of breakdown voltage.

- Unit

Volt (V)

- Standards

a) Measurement

NEMA uses the twisted wide pair method for testing all wire sizes down to AWG 44 (≥ 0.050 mm). NEMA does not stipulate a method for testing the breakdown voltage of wire above 44 AWG (≥ 0.05 mm). NEMA has the intention of adopting the IEC method in the near future.

Wires up to a diameter of 0.100 mm are tested according to IEC 60851-3.3 with a cylinder electrode, wrapping the wire once around a polished cylinder electrode with a defined load. Wire and electrode are connected to a high-voltage source. Then the voltage is increased consistently until breakdown of the insulation, thus testing the voltage strength of the insulation.

For wire above 0.100 mm the measurement acc. to IEC is carried out by a pair of twisted wire (twisted pair). The test voltage is connected to each wire. The test procedure corresponds to the cylinder electrode method but two insulation layers are tested.

JIS now gives the option of using the IEC cylinder electrode method for wires up to 0.10 mm, for wires above this diameter the twisted wire method is used.

b) Minimum values

The minimum breakdown voltage values are listed by diameter and build in the standards like NEMA or IEC 60317-0-1. This applies to various types of magnet wire except to those with a polyamide (nylon) top coat over a polyurethane base coat. Here the minimum values are reduced by approximately 8-15%. NEMA and JIS define the minimum values similarly.

c) Further development of international standards

NEMA only uses the twisted pair version indicating the minimum wire diameter of AWG 44. Therefore NEMA does not stipulate a method for testing the breakdown voltage of wires above AWG 44. NEMA has the intention of adapting the IEC method in future.

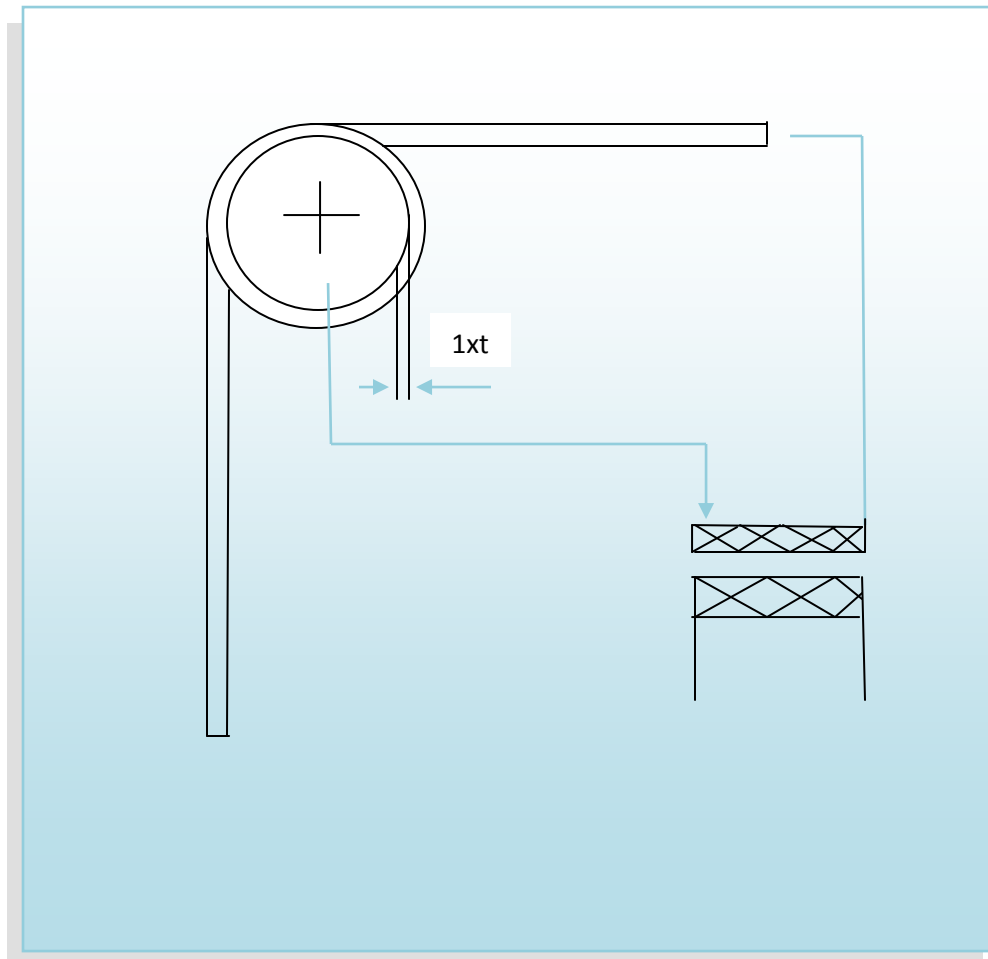

Glossary

NEMA – North American Electrical Manufacturing Association

IEC – International Electrical Commission